

# XTERNA - SOFT 30

## PER CHIUSURA RALLENTATA ANTA

## POUR LA FERMETURE FREINÉE DU VANTAIL

LATO MURO / CÔTÉ MUR

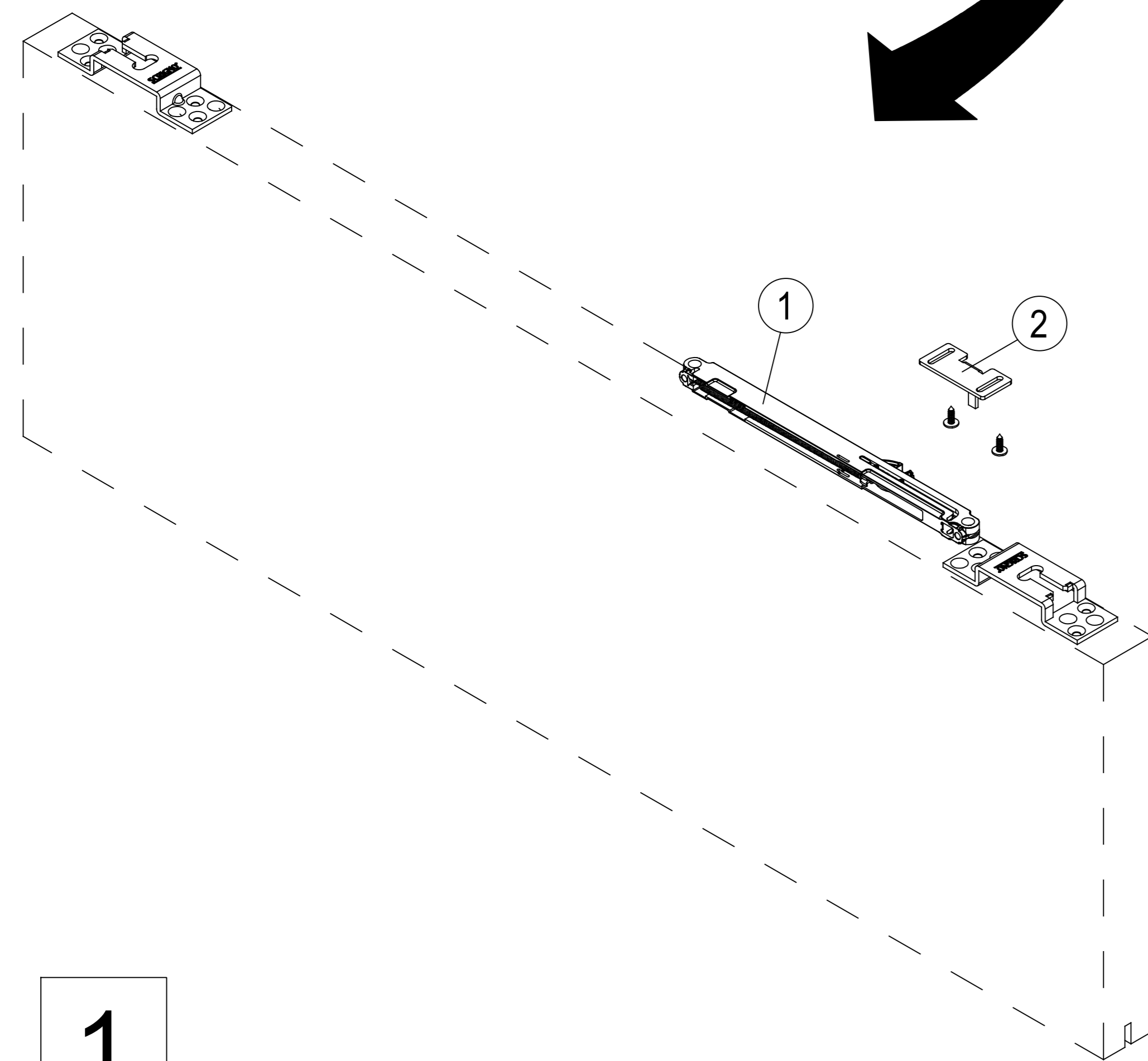
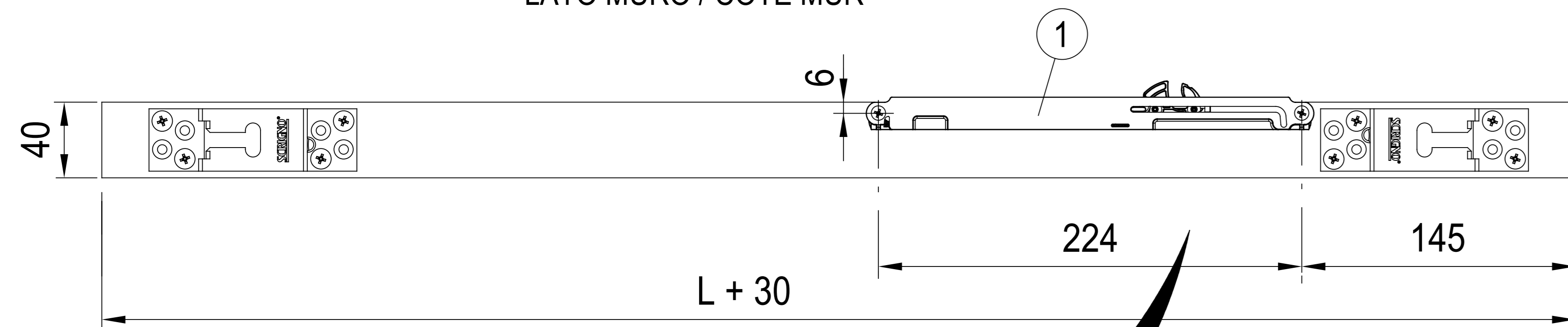

**1**

MONTARE IL FRENO (1) SULLA PARTE SUPERIORE DELL'ANTA PRESTANDO ATTENZIONE ALLE QUOTE INDICATE. FISSARE IL FRENO CON LE 2 VITI IN DOTAZIONE.

MONTER LE FREIN (1) SUR LA PARTIE SUPERIEURE DU VANTAIL EN PRETANT BIEN ATTENTION AUX DIMENSIONS INDIQUEES. FIXER LE FREIN AVEC LES 2 VIS FOURNIES.

### CONTENUTO CONFEZIONE - CONTENU DE L'EMBALLAGE

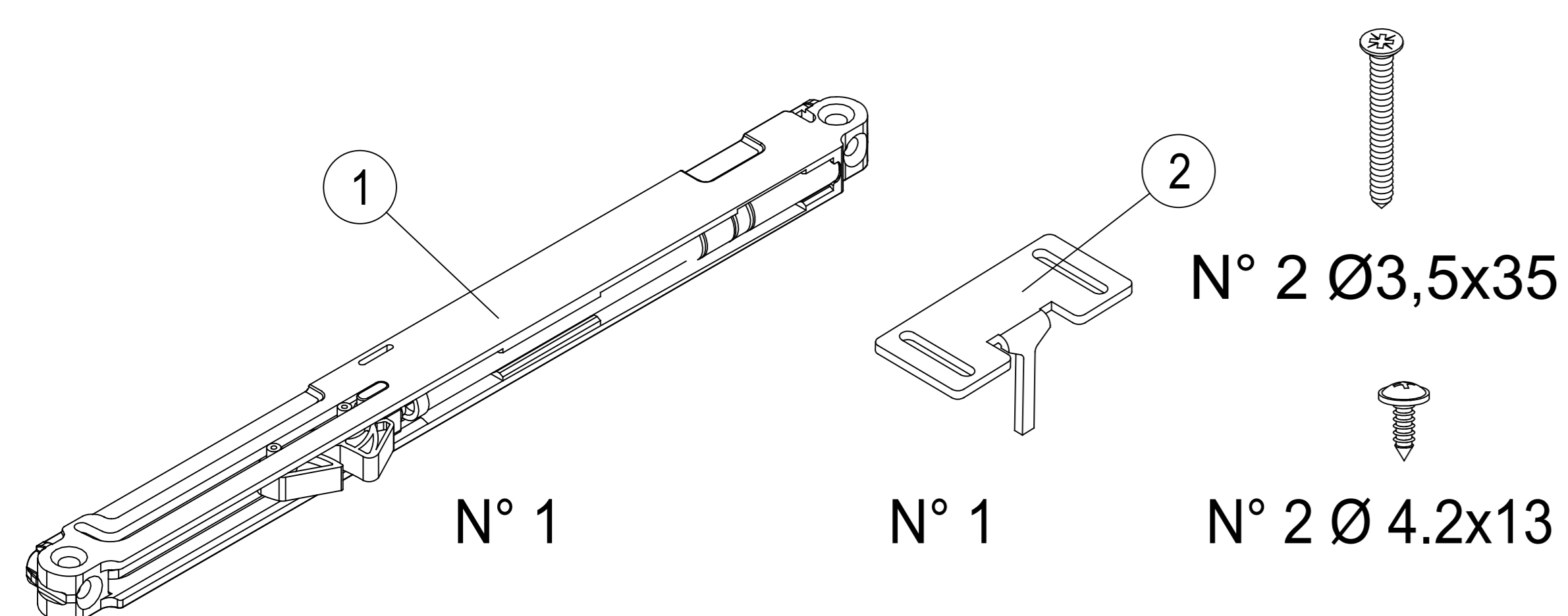

**2**

MONTARE L'ANTA E PORTARLA A BATTUTA SUL MONTANTE "B"

MONTER LE VANTAIL ET LE FAIRE COULISSER DE FAÇON A CE QU'IL VIENNE EN BUTEE CONTRE LE MONTANT "B"

IT  
FR

**MAX  
30Kg**

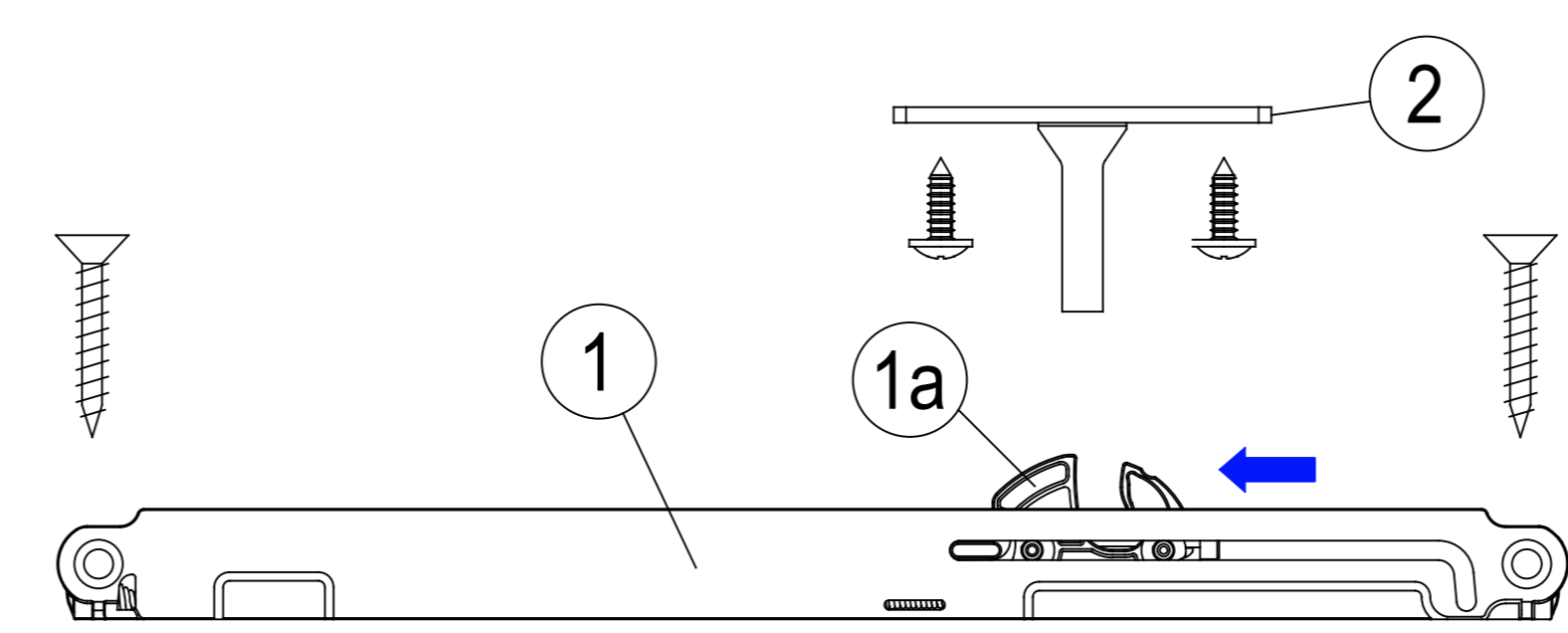

PRIMA DI DETERMINARE IL PUNTO DI FISSAGGIO DEL RISCONTRO (2) VERIFICARE CHE L'AZIONATORE (1a) SIA POSIZIONATO COME IN FIGURA

AVANT DE DÉTERMINER LE POINT DE FIXATION DE LA PLAQUE DE BUTÉE (2), VÉRIFIER QUE L'ACTIONNEUR (1a) SOIT POSITIONNÉ CONFORMÉMENT À LA FIGURE.

**3**

FISSARE CON LE VITI IN DOTAZIONE IL RISCONTRO (2) FACENDOLO COINCIDERE ALLA PROPRIA SEDE SUL FRENO  
REGOLARE LA PROFONDITA' DEL RISCONTRO FACENDOLO SCORRERE SULLE PROPRIE ASOLE, PRESTANDO ATTENZIONE CHE NON VADA AD INTERFERIRE CON LA PIASTRA DI SOSPENSIONE DEI CARRELLI

VISSER LES VIS SUR LA PLAQUE DE BUTEE (2), UTILISANT LES 2 VIS FOURNIES, EN FAISANT COINCIDER LA PLAQUE AVEC SON LOGEMENT SUR LE FREIN.

REGLER LA PROFONDEUR DE LA PLAQUE DE BUTEE EN LA DEPLACANT DANS SES TROUS OBLONS ET VEILLANT A CE QU'ELLE N'AILLE PAS FROTTER CONTRE LA PLAQUE DE SUSPENSION DES CHARIOTS.

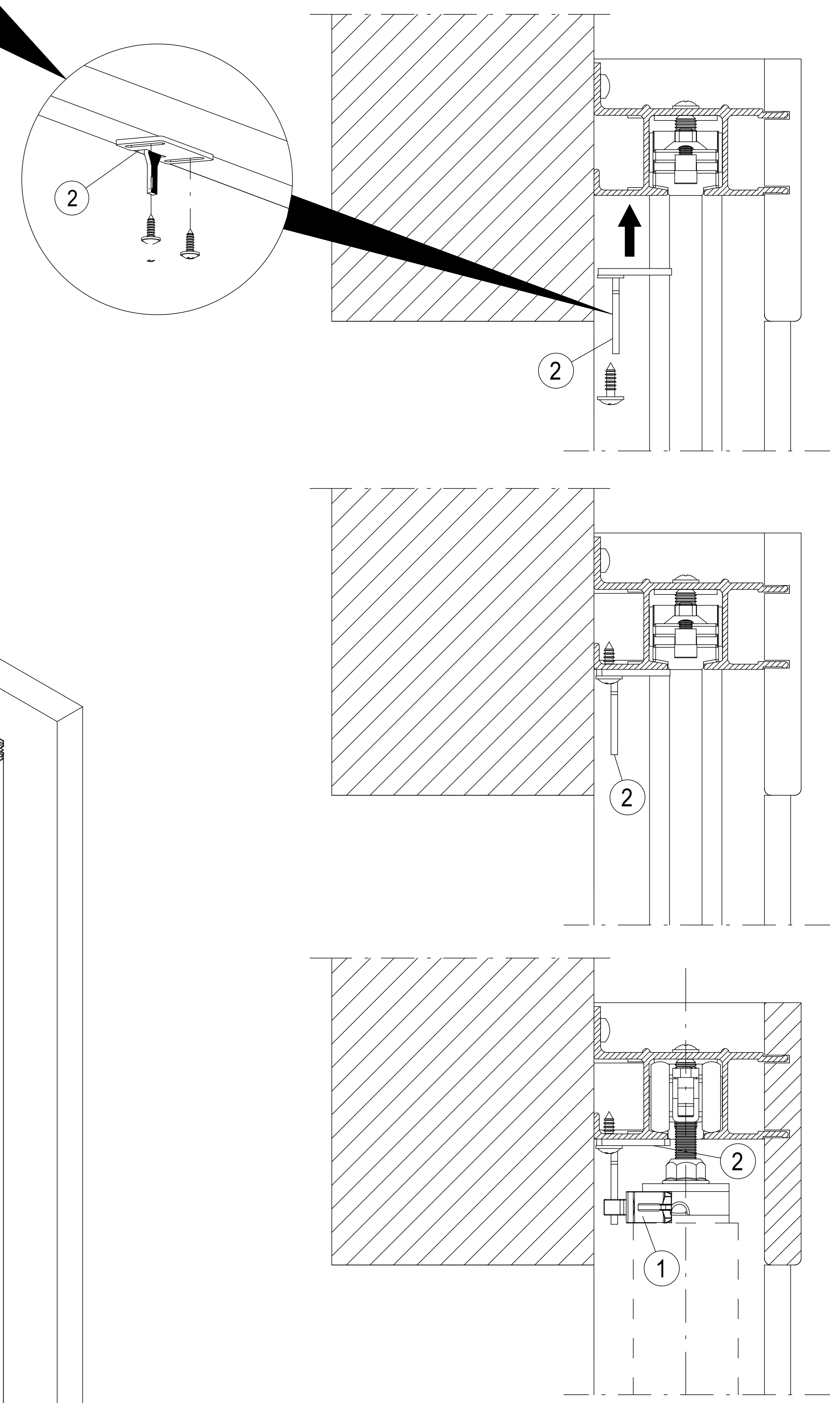

I dati pubblicati sono indicativi. SCRIGNO S.p.A. declina ogni responsabilità per le possibili inesattezze contenute, dovute ad errori di stampa, di trascrizione o per qualsiasi altro motivo e si riserva il diritto di apportare modifiche atte a migliorare i prodotti senza preavviso. La riproduzione anche parziale è severamente vietata a norme di legge.

Ces informations sont remises a titre indicatif. SCRIGNO S.p.A. declina toute responsabilité en cas d'erreur d'impression, de traduction, ou pour tout autre motif. Elle se réserve le droit d'apporter toute modification pour le montage et l'amélioration du produit sans preavis. Toute reproduction même partielle de ce document est formellement interdite.



**SCRIGNO<sup>®</sup> GOLD** XTERNA - SOFT 30  
FOR SLOW SLIDING DOOR CLOSURE  
PARA CIERRE RALENTIZADO DE LA HOJA

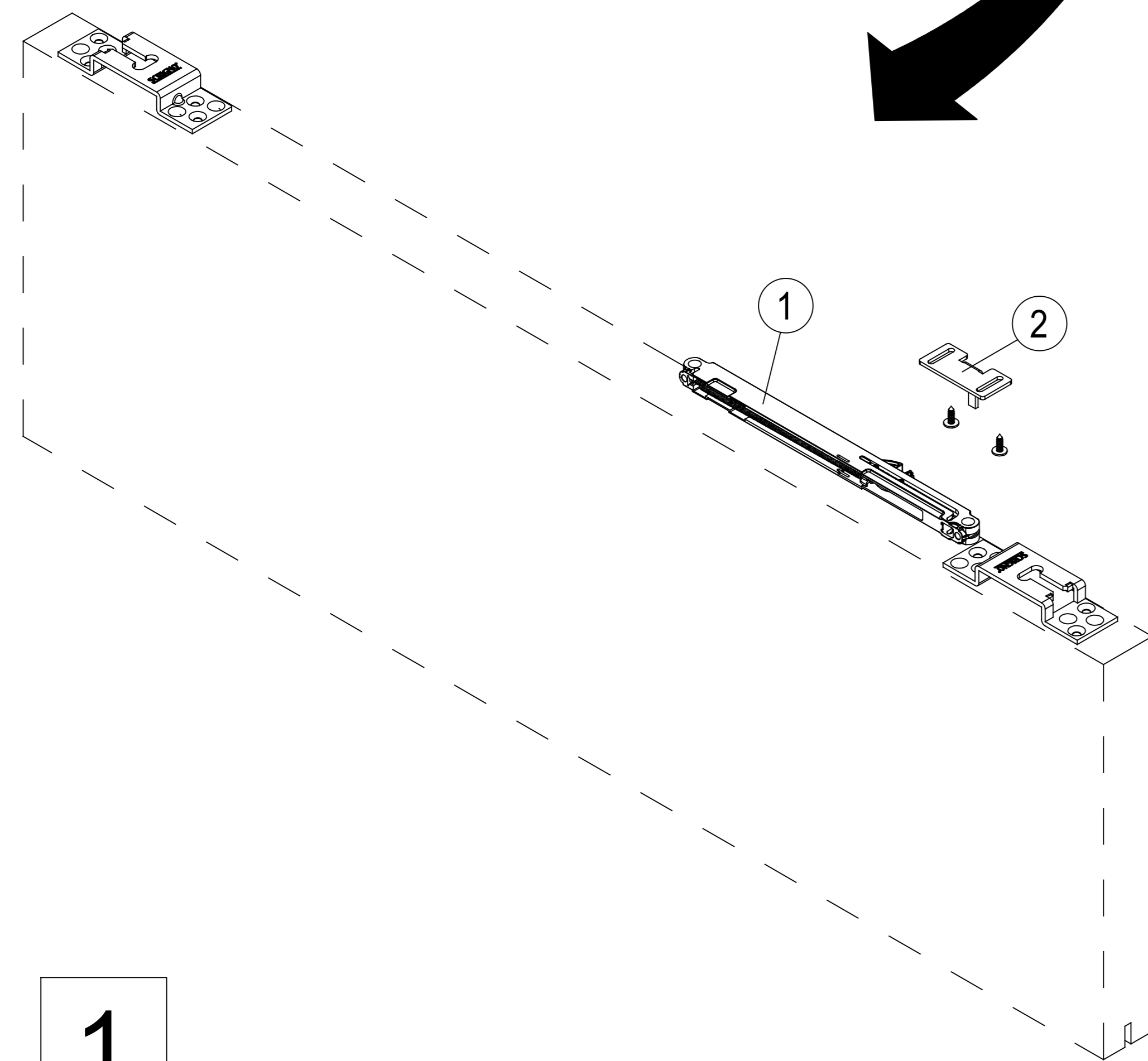
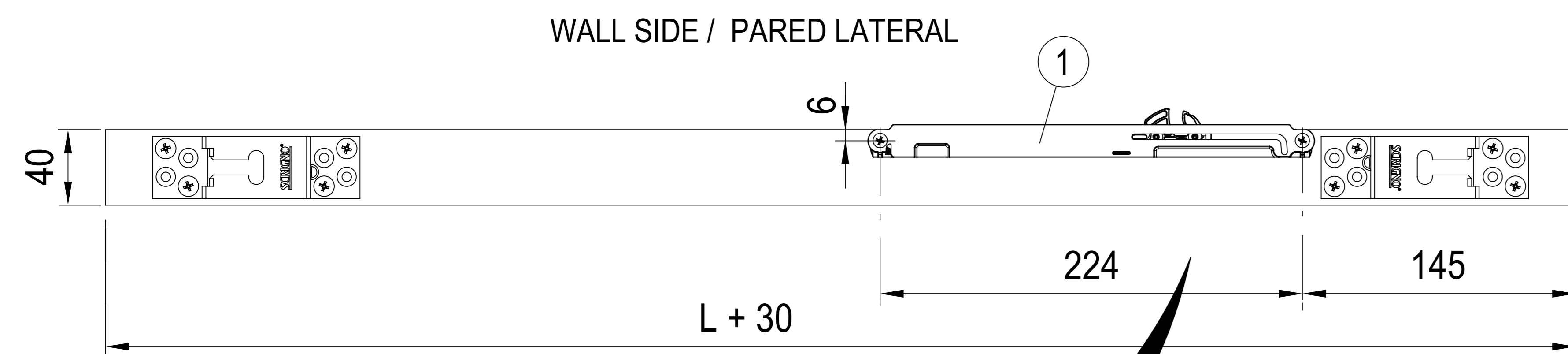

**1**

FIT THE BRAKE ONTO THE UPPER PART OF THE DOOR, TAKING CARE TO RESPECT THE DISTANCES INDICATED. FIX THE BRAKE WITH THE 3 SUPPLIED SCREWS.

INSTALAR EL FRENO EN LA PARTE SUPERIOR DE LA HOJA PRESTANDO ATENCIÓN A LAS COTAS INDICADAS. FIJAR EL FRENO CON LOS 3 TORNILLOS EN DOTACIÓN DE SERIE.

PACK CONTENTS - CONTENIDO CAJA

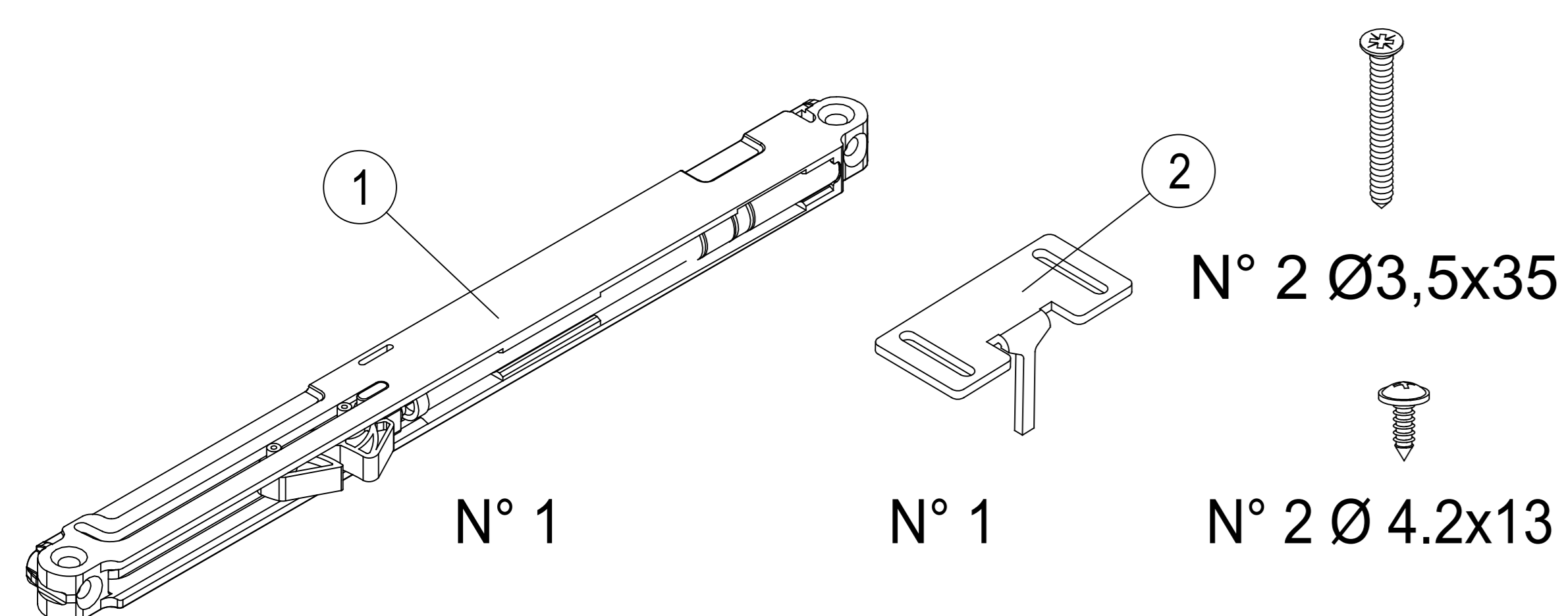

**2**

FIT THE DOOR AND BRING IT TOWARDS THE DOOR POST SUBFRAME "B".

MONTAR LA HOJA Y LLEVARLA HACIA EL BATIENTE HASTA QUE ESTÉ CERRADA

BEFORE DECIDING THE FIXING POINT FOR THE STRIKER PLATE "2", CHECK THAT THE OPERATING LEVER "1" IS POSITIONED AS SHOWN

ANTES DE DETERMINAR EL PUNTO DE FIJACIÓN DEL TOPE "2" COMPROBAR QUE EL ACCIONADOR "1" ESTÉ POSICIONADO SEGÚN SE MUESTRA EN LA FIGURA.

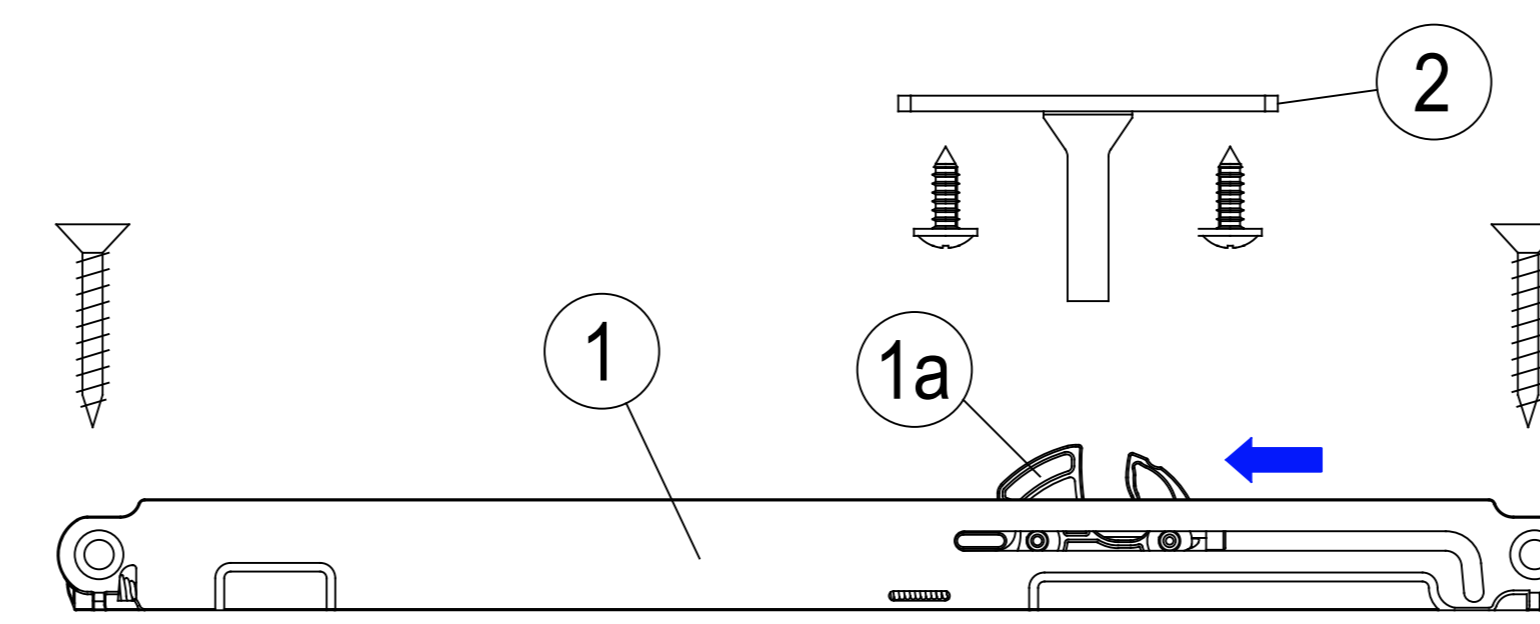

**3**

FASTEN THE STRIKER PLATE "2" WITH THE SUPPLIED SCREWS SO THAT IT FITS INTO ITS RECESS ON THE BRAKE.  
ADJUST THE DEPTH OF THE STRIKER PLATE BY SLIDING IT ALONG ITS SLOTS, TAKING CARE THAT IT DOES NOT INTERFERE WITH THE SUSPENSION PLATE OF THE HANGERS.

AJUSTAR LOS TORNILLOS EN EL TOPE DEL FRENO HACIÉNDOLO COINCIDIR CON EL FRENO, UTILIZANDO LOS 2 TORNILLOS EN DOTACIÓN DE SERIE.

REGULAR LA PROFUNDIDAD DEL TOPE DEL FRENO POR DESLIZAMIENTO EN LAS RANURAS, PRESTANDO ATENCIÓN QUE NO INTERFIERA CON LA PLACA DE SUSPENSIÓN DE LOS CARRITOS

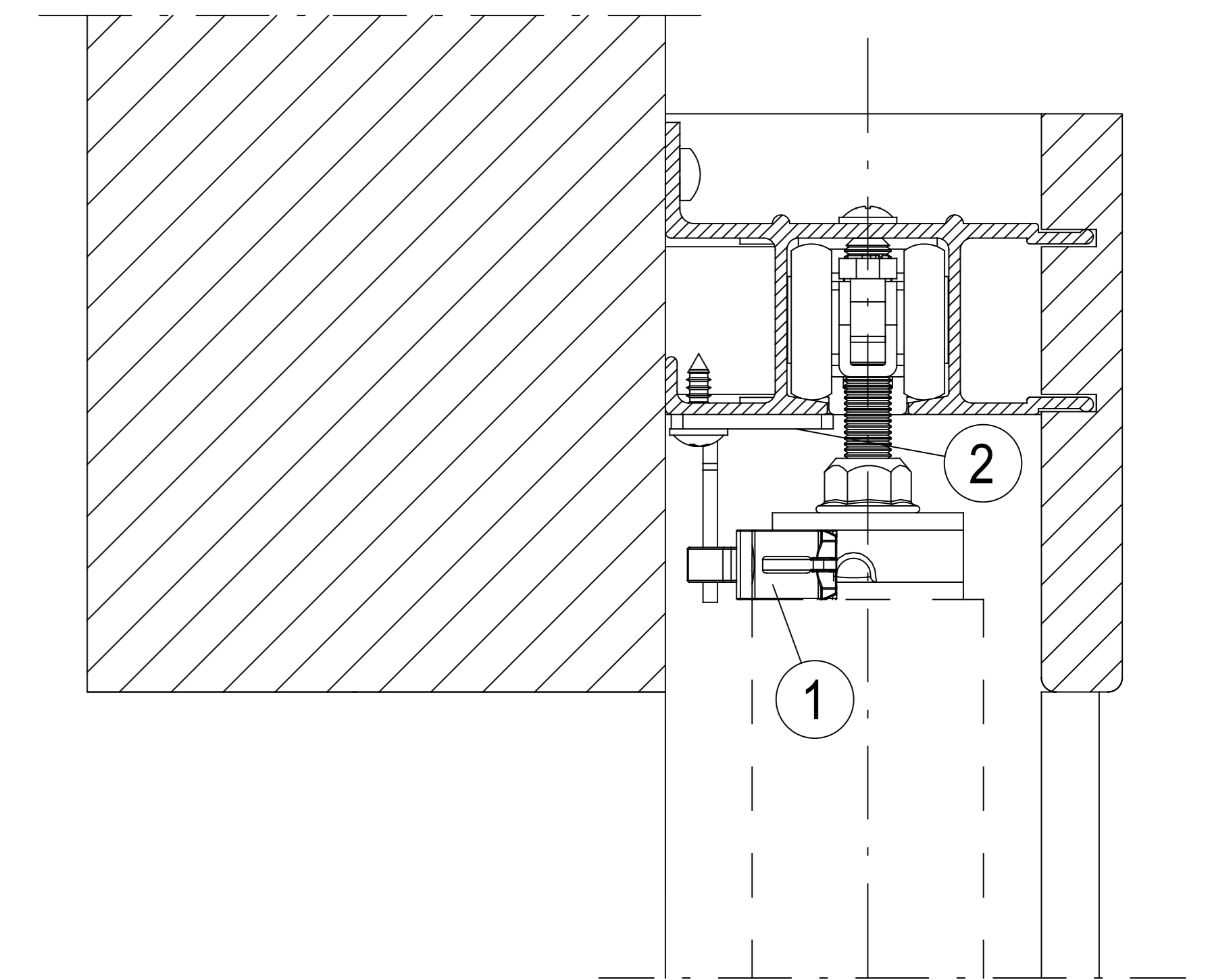
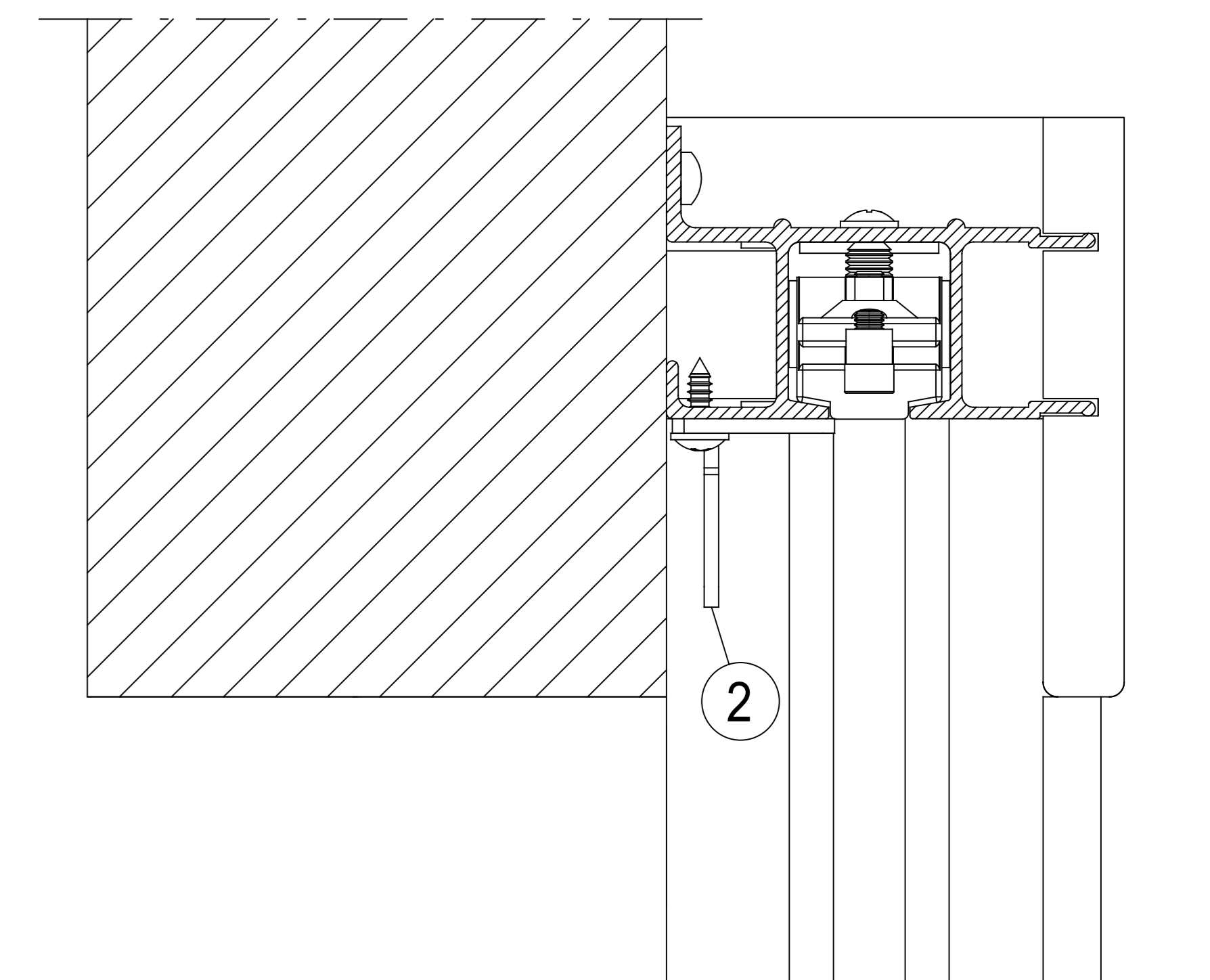
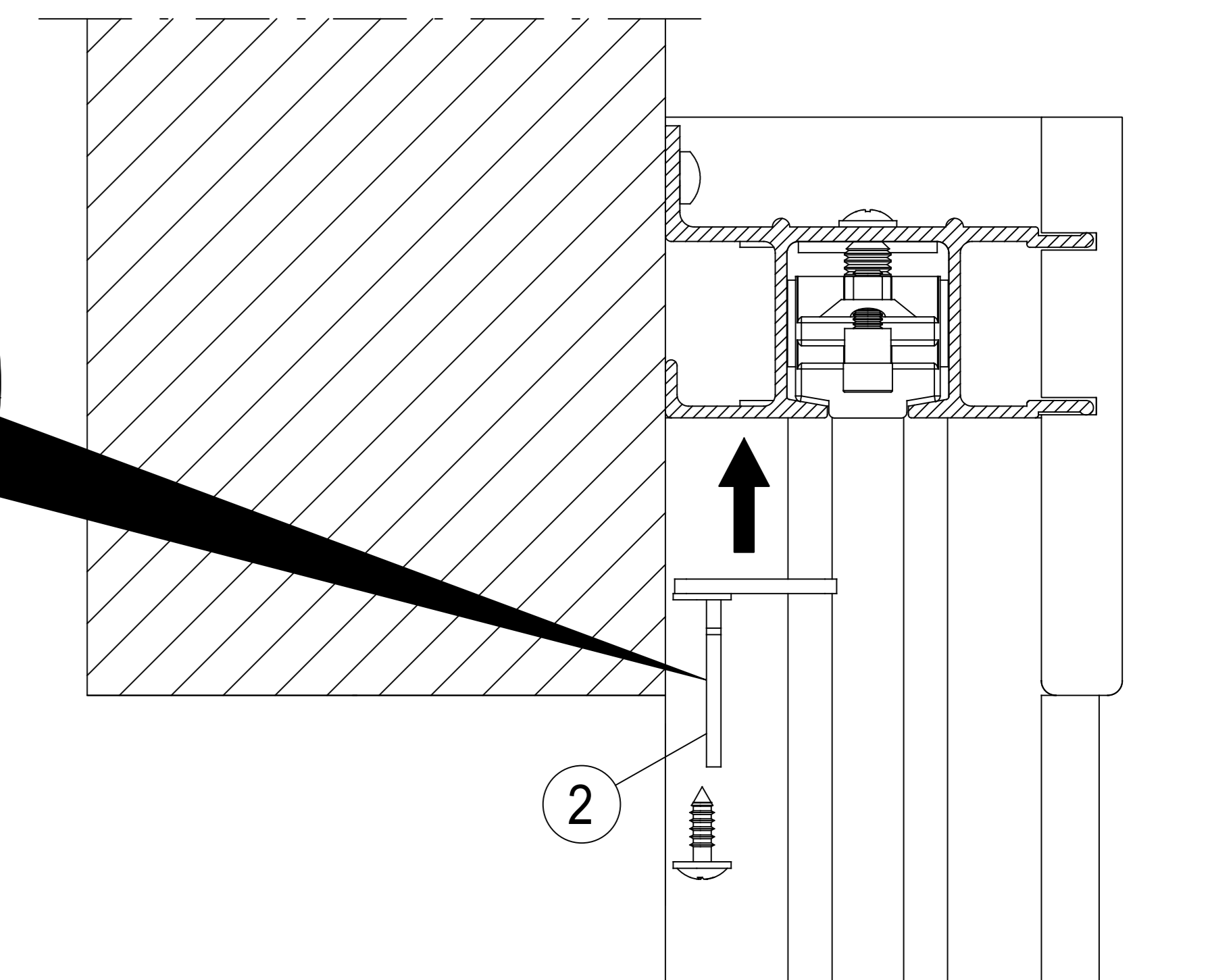
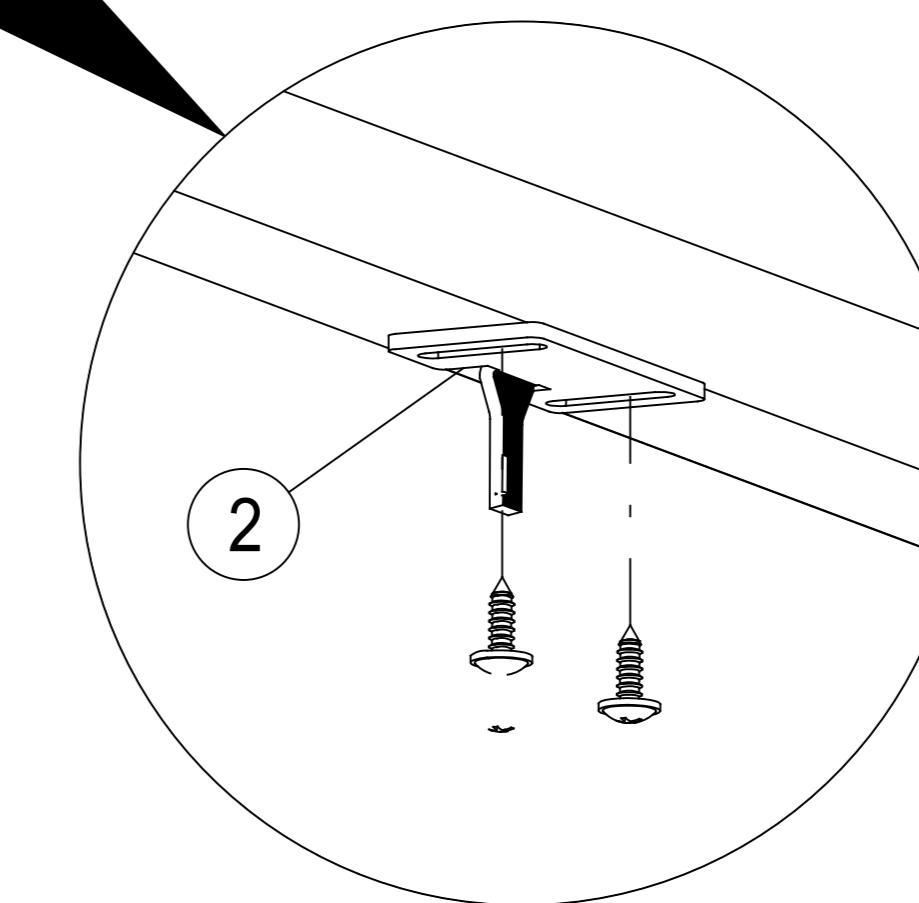

EN  
ES

The information given in this document is for descriptive purposes only. SCRIGNO S.p.A. will not be held responsible for any inaccuracies caused by printing errors, transcription errors or for any other reason, and reserves the right to make modifications, without giving prior notice, for the improvement of its products. The reproduction, including the partial reproduction, of this document is severely prohibited within the terms of the Law.

Los datos publicados son indicativos. La sociedad SCRIGNO S.p.A. declina toda responsabilidad por los posibles errores contenidos, debido a errores de imprenta, de transcripción o cualquier otro motivo y se reserva el derecho de mejorar los productos sin previo aviso. La reproducción total o parcial está prohibida por la ley.

**SCRIGNO<sup>®</sup>**  
Scrigno SpA | scrigno.net  
via Casale Sant'Ermete 975  
47822 Santarcangelo di Romagna (RN)  
ph. + 39 0541 757711  
fax + 39 0541 757780  
scrigno@scrigno.it

IS-0075