

GRANLUCE 190 PLATINUM

INSTALLAZIONE PORTA-MONTAGE DE LA PORTE-COLOCACION DE LA PUERTA-MONTAGE DER TÜR-INSTALLATION DOOR

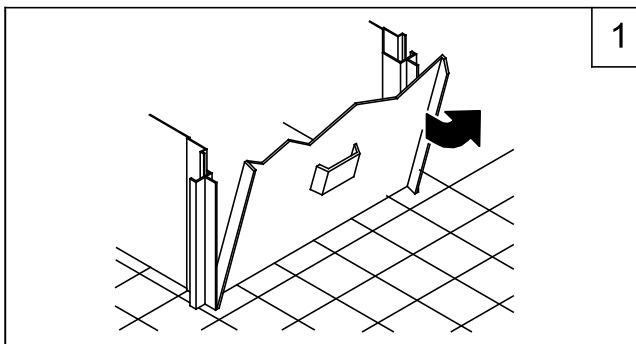

- I TOGLIERE LA MASCHERINA DI COPERTURA SOLO A MATURAZIONE AVVENUTA DELL'INTONACO. PULIRE ACCURATAMENTE L'INTERNO DEL CASSONETTO.
- F ENLEVER LA PLAQUE DE PROTECTION ET NETTOYER L'INTERIEUR DU CHASSIS.
- E QUITAR LA TAPA DE CIERRE DESPUES QUE HAYA FRAGUADO EL ENFOSCADO. LIPIAR CUIDOSAMENTE EL INTERIOR DEL ARMAZON.
- D DIE SCHUTZHÜLLE ERST NACH VOLLSTÄNDIGEM AUSTROCKNEN DES PUTZES ENTFERNEN UND KASTEN IM INNERN REINIGEN.
- GB REMOVE FRAME COVER AND SPACER. CLEAN INTERNAL SPACE.

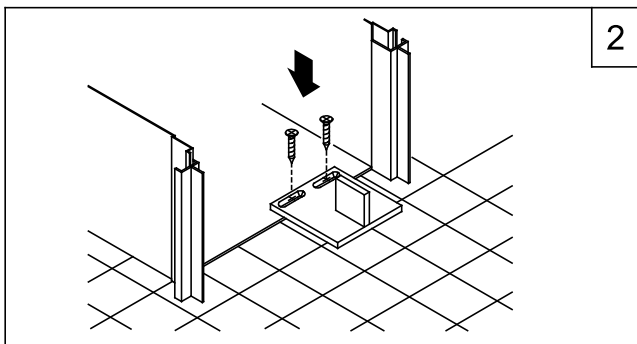

- I FISSARE IL NASELLO DI GUIDA AI FORI PREDISPOSTI ALL'INTERNO DEL CASSONETTO UTILIZZANDO LE VITI IN DOTAZIONE.
- F FIXER LE GUIDE EN UTILIZANT LES TROUS A L'INTERIEUR DU CHASSIS, L'AIDE DES VIS FOURNIES.
- E FIJAR LA PESTAÑA DE GUIA EN LOS TALADROS PREVISTOS EN EL INTERIOR DEL ARMAZON UTILIZANDO LOS TORNILLOS DISPONIBLES.
- D DIE TÜRFÜHRUNG MITTEL DEN MITGELIFERTEN SCHRAUBEN IM INNERN DES KASTENS FIXIEREN.
- GB FIX FLOOR GUIDE TO CENTRE OF FRAME IN PRE-DRILLED HOLES USING FIXNGS PROVIDED.

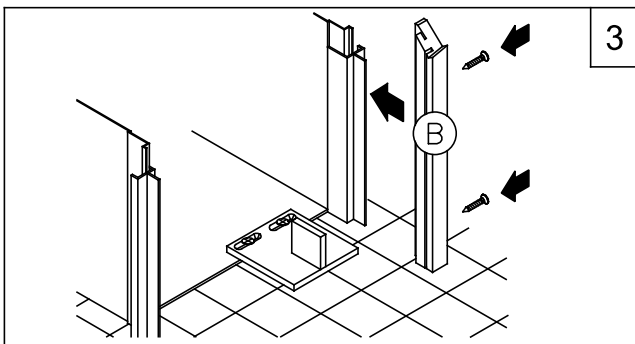

- I INCASTRARE UN MONTANTE (B) NELL'APPOSITA LAMELLA. FORARE MONTANTE E LAMIERA E FISSARE CON VITI AUTOFILETTANTI.
- F ENCASTRER UN MONTANT (B) DANS LA BORDURE VERTICALE DU CHASSIS ET LE FIXER AVEC DES VIS AUTOFOREUSES.
- E ENCAJAR UN MONTANTE (B) EN EL COSTADO DEL PREMARCO. TALADRAR MONTANTE Y COSTADO Y FIJAR CON TORNILLOS AUTORROSCANTES.
- D NUR EINEN DER (B) TÜRPFOSTEN IN DIE VORGESEHENE LAMELLE EINSpanNEN UND MIT SELBSTSCHNEIDENDEN SCHRAUBEN BEFESTIGEN. (DABEI TÜRPFOSTEN UND BLECH DURCHLÖCHERN).
- GB FIT JAMB (B) ON THE BOX FRAME. IT IS HELPFUL TO DRILL THE METAL SHEET PREDEILL AND FIX WITH SCREWS.

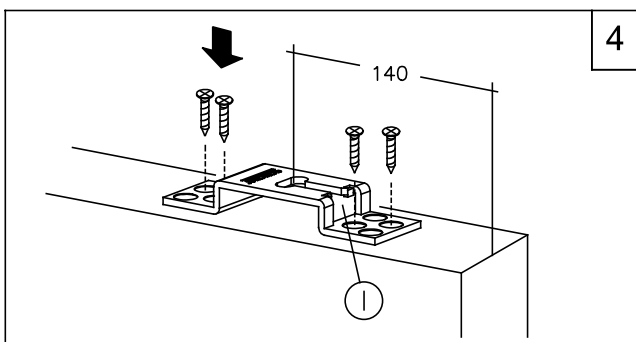
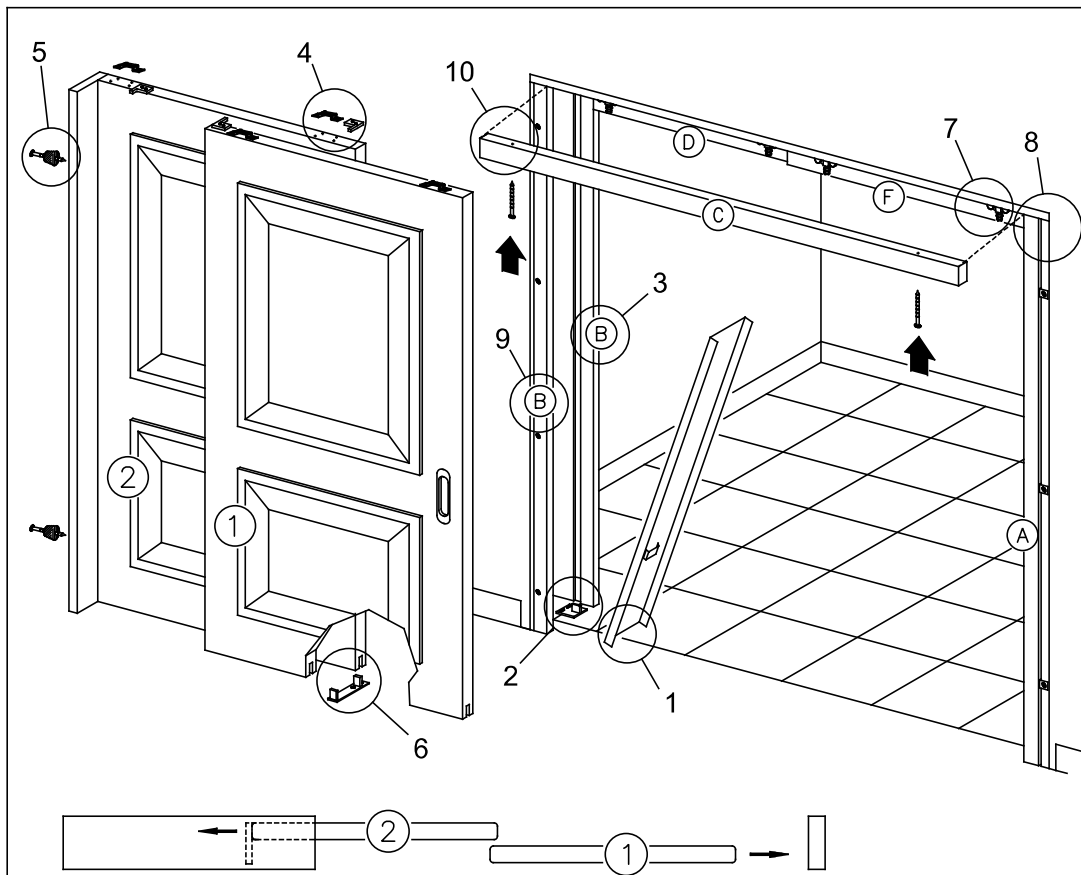

- I FISSARE LE STAFFE DI SOSPENSIONE ALLA PORTA TENENDO L'INCAVO (I) PER L'AGGANCIAMENTO DEL CARRELLO VERSO IL LATO ANTERIORE DELLA PORTA.
- F FIXER LES ETRIERS DE SUSPENSION SUR LA PORTE EN VEILLANT A CE QUE L'OUVERTURE (I) AMENAGEE POUR L'ACCROCHAGE DU CHARIOT SE TROUVE VERS LE COTE ANTERIEUR DE LA PORTE.
- E FIJAR LAS GARRAS DE SUJECION A LA PUERTA MANTENIENDO LA CAVIDAD (I) PARA LA FIJACION DEL CARRO ORIENTADA HACIA EL LADO DELANTERO DE LA PUERTA.
- D DIE AUFHÄNGEBÜGEL AN DER TÜR BEFESTIGEN; HIERBEI MUSS DIE ÖFFNUNG (I) FÜR DAS EINHAKEN DES ROLLWAGENS ZUR VORDERSEITE DER TÜR GERICHTET SEIN.
- GB FIX SUSPENSION BRACKETS TO DOOR, WITH THE SLOT (I) FOR HOOKING ONTO HANGER TOWARDS FRONT SIDE OF DOOR

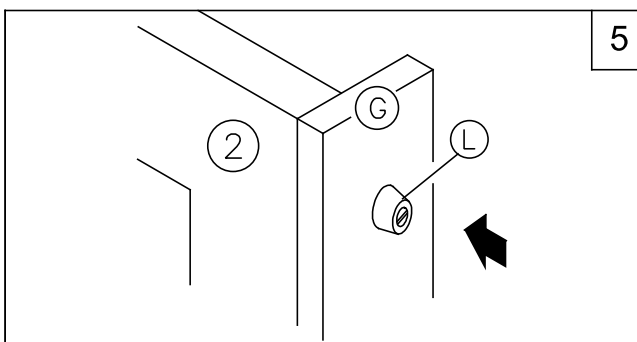

- I FISSARE IL MONTANTE (G) E I GOMMINI DI BATTUTA (L) SUL FIANCO POSTERIORE DELLA PORTA (2).
- F FIXER LE MONTANT (G) ET LES BUTEES DE CAOUTCHOUC (L) DERIERE LA PORTE (2).
- E FIJAR EL MONTANTE (G) E LOS TOPES DE GOMA (L) EN EL COSTADO POSTERIOR DE LA PUERTA (2).
- D DEN TÜRPFOSTEN (G) UND DIE GUMMI-PUFFER AUF DER HINTERSEITE DER TÜR MONTIEREN. 2
- GB FIX THE JAMB (G) AND POSITION RUBBER BUFFER TO REAR EDGE OF THE PANEL (2).

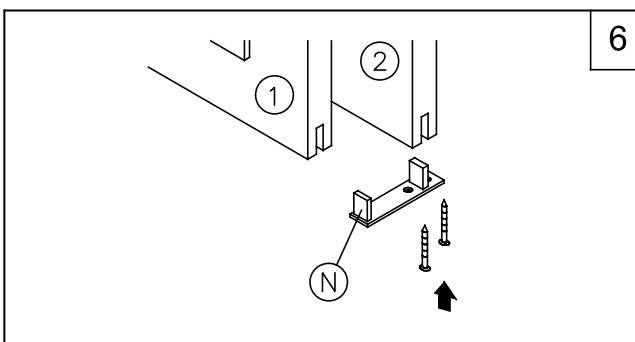

- I FISSARE IL NASELLO (N) ALL'ESTREMITA' ANTERIORE DELLA PORTA (2)
- F FIXER LE GUIDE A L'EXTREMITÉ DELA PORTE (2)
- E FIJAR LA PESTAÑA DE GUIA AN LA PARTE ANTERIOR DE LA PUERTA (2)
- D DIE TÜRFÜHRUNG AN DIE EXTREMITÄT DIE TÜR (2) MONTIEREN
- GB FIX THE DOORGUIDE ON FRONTEND OF DOOR (2)

IN DOTAZIONE-EN DOTATION-EN DOTACION-ZUBEHOR-PACK CONTENTS

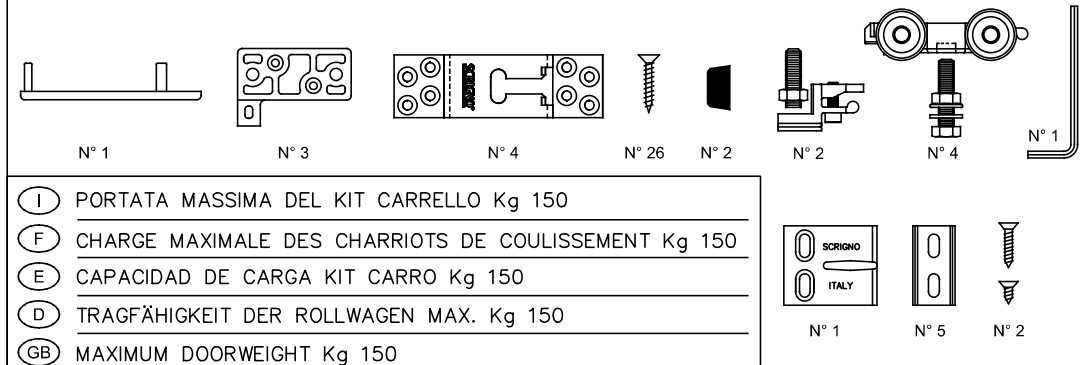

- I PORTATA MASSIMA DEL KIT CARRELLO Kg 150
- F CHARGE MAXIMALE DES CHARRIOTS DE COULISSEMENT Kg 150
- E CAPACIDAD DE CARGA KIT CARRO Kg 150
- D TRAGFÄHIGKEIT DER ROLLWAGEN MAX. Kg 150
- GB MAXIMUM DOORWEIGHT Kg 150

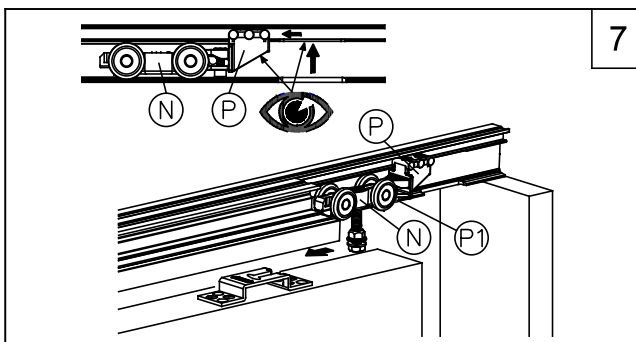

- I INTRODURRE I CARRELLI (N) E IL FERMO (P) NELL'APPOSITA ASOLA. AGGANCIARE LA PORTA E REGOLARE LO SCORRIMENTO. TRAMITE LA VITE (P1) REGOLARE L'AGGANCIAMENTO DELLA PORTA AL FERMO.
- F INTRODUIRE LES CHARIOTS (N) ET LA BUTEE D'ARRET DANS LE LOGEMENT RESERVE. POSITIONNER LA PORTE ET EN REGLER LE COULISSEMENT. UTILISER LA VIS (P1) POUR REGLER LA FIXATION DE LA PORTE A LA BUTEE D'ARRET.
- E INTRODUCIR LOS CARROS (N) Y EL TOPE (P) EN EL OJAL PREDISPUETO PARA ALOJARLOS. ENGARZAR LA PUERTA Y REGULAR SU DESLIZAMIENTO. POR MEDIO DEL TORNILLO, (P1) AJUSTAR EL ENGANCHE DE LA PUERTA AL TOPE.
- D DEN ROLLWAGEN (N) UND DEN ANSCHLAG (P) IN DIE VORGESEHENE SCHIENE EINFÜGEN. DIE TÜR EINHAKEN UND DEREN GleITBEWEGUNG REGELN. ÜBER DIE SCHRAUBE (P1) DIE EINHAUKUNG DER TÜR AM ANSCHLAG REGELN.
- GB FIT THE HANGERS (N) AND THE STOP (P) INTO THE SPECIFIC SLOT. HOOK ON THE DOOR AND ADJUST FOR CORRECT SLIDING MOVEMENT. USE SCREW (P1) TO ADJUST HOOKING OF DOOR TO STOP.

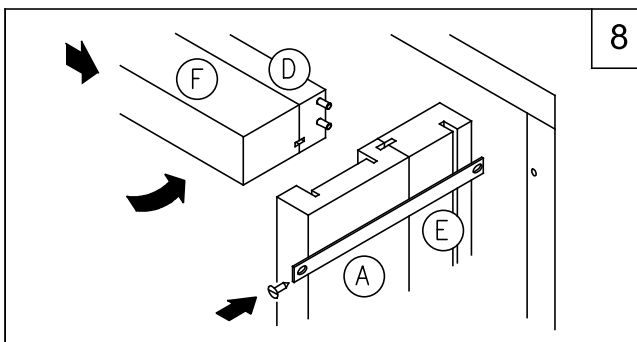

- I INSERIRE IL TRAVERSO (D+F) SUL MONTANTE (B) PRECEDENTEMENTE FISSATO, INCASTRARE IL MONTANTE DI BATTUTA (A+E) E FISSARLO IN POSIZIONE.
- F INTRODUIRE LA TRAVERSE (D+F) DANS LE MONTANT (B) DEJA INSTALLE, POSITIONNER LE MONTANT (A+E) .FIXER LE MONTANT (A+E)
- E ENCAJAR EL TRAVERSAÑO (D+F) AL MONTANTE (B), FIJADO ANTERIORMENTE, COLOCAR EL MONTANTE DE CIERRE (A+E) Y FIJARLO.
- D QUERSTREBE (D+F) AN DEN SCHON BEFESTIGTEN TÜRPFOSTEN (B) UND GLEICHZEITIG DEN TÜRPFOSTEN (A+E) EINSpanNEN. DIESEN LOTRECHT AN DEN STÄNDER ANDÜBELN.
- GB SLOT CROSS PIECE (D+F) TO JAMB (B) (ALREADY FITTED) AND AT THE SAME TIME SLOT IN JAMB (A+E)

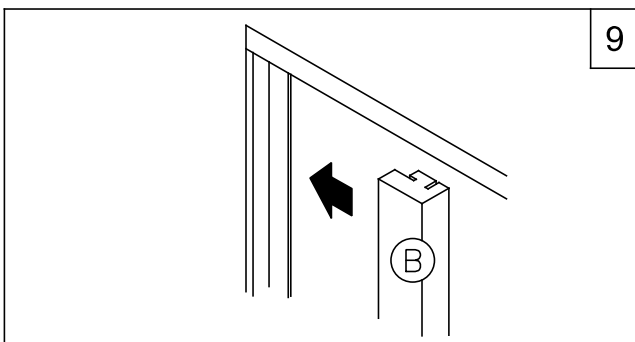

- I FISSARE IL SECONDO MONTANTE (B)
- F FIXER LE MONTANT (B) RESTANT.
- E FIJAR EL SEGUNDO MONTANTE (B)
- D DEN ANDEREN TÜRPFOSTEN (B) MONTIEREN.
- GB FIT THE REMAINING JAMB (B)

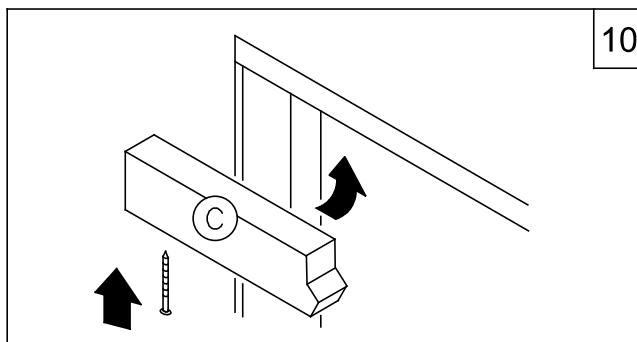

- I AVVITARE IL SECONDO TRAVERSO (C). (ASPORTABILE PER EVENTUALI REGOLAZIONI O MANUTENZIONI).
- F INSTALLER LA TRAVERSE (C) DE SORTE QU'ELLE PUISSE ETRE DEMONTEE POUR D'EVENTUELLES INTERVENTIONS DE REGLAGE OU D'ENTRETIEN.
- E ATORNILLAR EL SEGUNDO TRAVERSAÑO (C). (DESMONTABLE PARA EFECTUAR POSIBLES REGULACIONES).
- D DIE QUERSTREBE (C) NUR MIT SCHRAUBEN BEFESTIGEN, DAMIT SIE FÜR EVENTUELLE REGULUNGEN ABMONTIERT WERDEN KANN.
- GB FIT CROSS PIECE (C) SO THAT IT CAN BE REMOVED EASILY FOR ADJUSTMENT OR ROUTINE MAINTENANCE PURPOSES.

I dati pubblicati sono indicativi. SCRIGNO S.p.A. declina ogni responsabilità per le possibili inesattezze contenute, dovute ad errori di stampa, di trascrizione o per qualsiasi altro motivo e si riserva il diritto di apportare modifiche atte a migliorare i prodotti senza preavviso. La riproduzione anche parziale è severamente vietata a norme di legge.

Ces informations sont remises à titre indicatif. SCRIGNO S.p.A. décline toute responsabilité en cas d'erreur d'impression, de traduction, ou pour tout autre motif. Elle se réserve le droit d'apporter toute modification pour le montage et l'amélioration du produit sans préavis. Toute reproduction même partielle de ce document est formellement interdite.

Los datos publicados son indicativos. La sociedad SCRIGNO S.p.A. declina toda responsabilidad por los posibles errores contenidos, debido a errores de imprenta, de transcripción o cualquier otro motivo y se reserva el derecho de mejorar los productos sin previo aviso. La reproducción total o parcial esta prohibida por la ley.

Bei den veröffentlichten Daten handelt es sich um Richtwerte. Die Scrigno S.p.A. lehnt jegliche Haftung für auf Druckfehler oder andere Ursachen zurückzuführende Ungenauigkeiten ab, und behält sich das Recht vor, jederzeit ohne Vorankündigung Verbesserungen am Produkt vorzunehmen. Der Nachdruck ist auch auszugsweise gesetzlich untersagt.

The information given in this document is for descriptive purposes only. SCRIGNO S.p.A. will not be held responsible for any inaccuracies caused by printing errors, transcription errors or for any other reason, and reserves the right to make modifications, without giving prior notice, for the improvement of its products. The reproduction, including the partial reproduction, of this document is severely prohibited within the terms of the Law.

SCRIGNO ITALY

Scrigno SpA | scrigno.com
via Casale Sant'Ermete 9/75
47822 Santarcangelo di Romagna (RN)
ph. +39 0541 757711
scrigno@scrigno.it

IS-0352

ANTE E STIPITI-PORTES ET KIT FINITION-HOJAS Y LOS MARCOS-TÜREN UND TÜRPFOSTEN-DOORS AND END POSTS

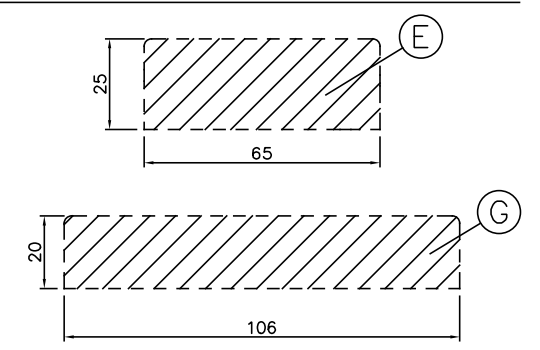
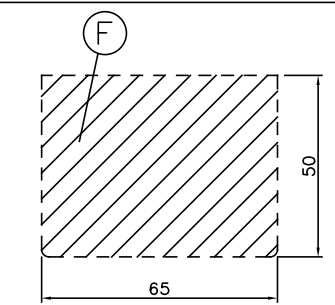
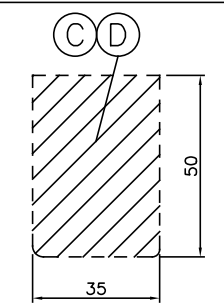
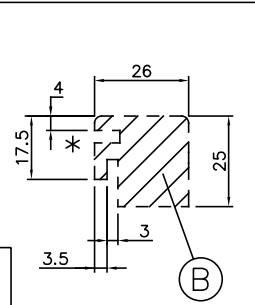
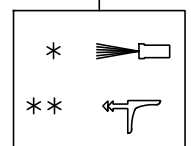
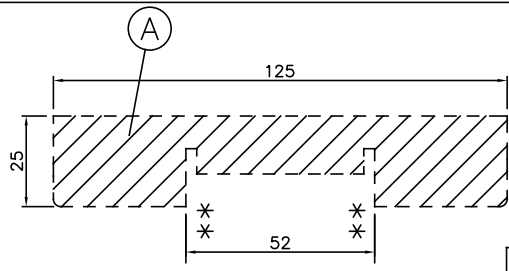
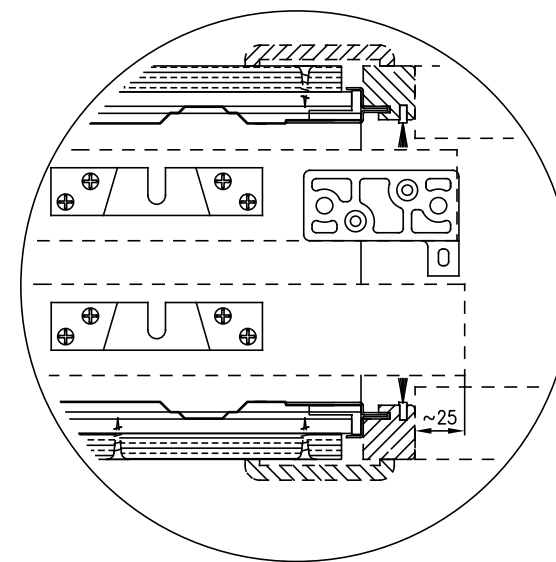
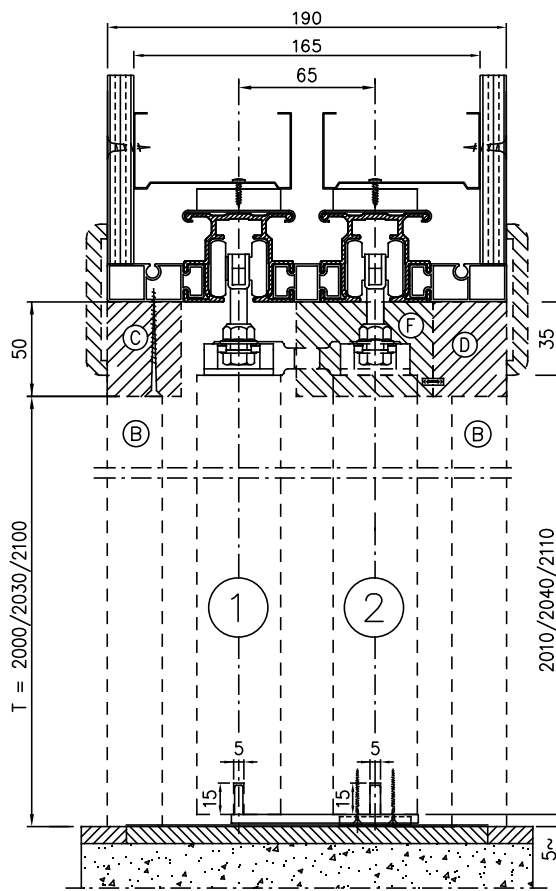

DIMENSIONI PANNELLO-DIMENSIONS DES PORTES-MEDIDAS DE LAS HOJAS-TÜRMASSE-DOOR DIMENSIONS

SINGOLO-SIMPLES-UNA HOJA-EINFÜGELIG-SINGLE		
P x T	N	L x H
1200x2000/2030/2100	2	615 x 2010/2040/2110
1400x2000/2030/2100	2	715 x 2010/2040/2110
1600x2000/2030/2100	2	815 x 2010/2040/2110
1800x2000/2030/2100	2	915 x 2010/2040/2110
2000x2000/2030/2100	2	1015 x 2010/2040/2110
2200x2000/2030/2100	2	1115 x 2010/2040/2110
2400x2000/2030/2100	2	1215 x 2010/2040/2110
DOPPIO-DOUBLES-DOS HOJAS-ZWEIFLÜGELIG-DOUBLE		
P x T	N	L x H
2400x2000/2100	4	615 x 2010/2040/2110
2800x2000/2100	4	715 x 2010/2040/2110
3200x2000/2100	4	815 x 2010/2040/2110
3600x2000/2100	4	915 x 2010/2040/2110
4000x2000/2100	4	1015 x 2010/2040/2110
4400x2000/2100	4	1115 x 2010/2040/2110
4800x2000/2100	4	1215 x 2010/2040/2110

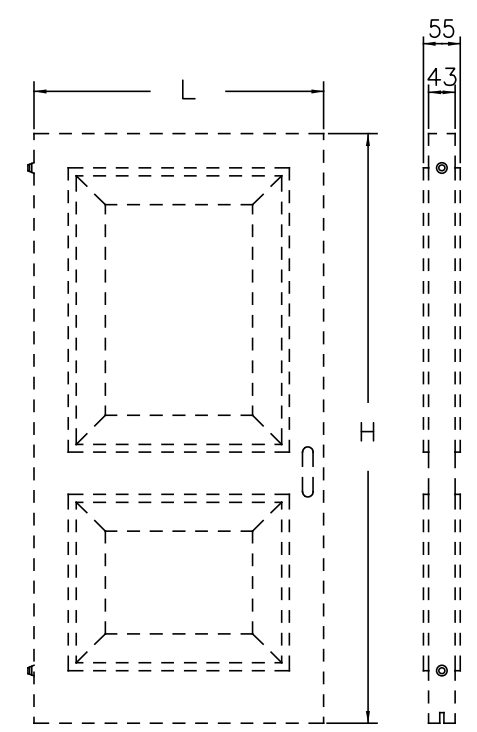

STIPITI-KIT FINITION-MARCO-TÜRPFOSTEN-END POSTS

SEMPLICE-SIMPLES-UNA HOJA-EINFACH-SINGLE												
P x T	A	B	E	C		D		F		G		
	N	N	N	mm	N	mm	N	mm	N	mm	N	mm
1200x2000	1	2	1	2050	1	1195	1	1195	1	575	1	2010
1200x2030				2080								2040
1200x2100				2150								2110
1400x2000	1	2	1	2050	1	1395	1	1395	1	675	1	2010
1400x2030				2080								2040
1400x2100				2150								2110
1600x2000	1	2	1	2050	1	1595	1	1595	1	775	1	2010
1600x2030				2080								2040
1600x2100				2150								2110
1800x2000	1	2	1	2050	1	1795	1	1795	1	875	1	2010
1800x2030				2080								2040
1800x2100				2150								2110
2000x2000	1	2	1	2050	1	1995	1	1995	1	975	1	2010
2000x2030				2080								2040
2000x2100				2150								2110
2200x2000	1	2	1	2050	1	2195	1	2195	1	1075	1	2010
2200x2030				2080								2040
2200x2100				2150								2110
2400x2000	1	2	1	2050	1	2395	1	2395	1	1175	1	2010
2400x2030				2080								2040
2400x2100				2150								2110

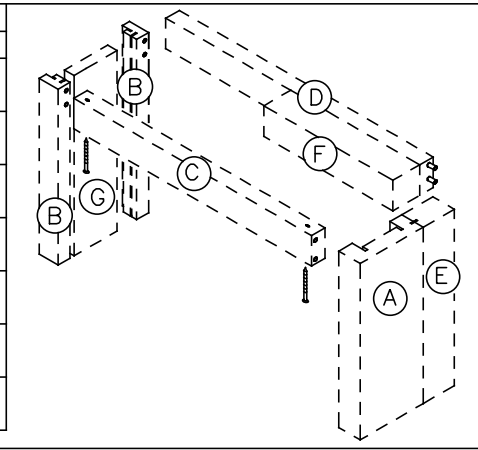

DOPPIO-DOUBLES-DOS HOJAS-DOPPELT-DOUBLE

P x T	A	B	E	C		D		F		G		
	N	N	N	mm	N	mm	N	mm	N	mm	N	mm
2400x2000	-	4	-	2050	2	1200	2	1200	2	575	2	2010
2400x2030				2080								2040
2400x2100				2150								2110
2800x2000	-	4	-	2050	2	1400	2	1400	2	675	2	2010
2800x2030				2080								2040
2800x2100				2150								2110
3200x2000	-	4	-	2050	2	1600	2	1600	2	775	2	2010
3200x2030				2080								2040
3200x2100				2150								2110
3600x2000	-	4	-	2050	2	1800	2	1800	2	875	2	2010
3600x2030				2080								2040
3600x2100				2150								2110
4000x2000	-	4	-	2050	2	2000	2	2000	2	975	2	2010
4000x2030				2080								2040
4000x2100				2150								2110
4400x2000	-	4	-	2050	2	2200	2	2200	2	1075	2	2010
4400x2030				2080								2040
4400x2100				2150								2110
4800x2000	-	4	-	2050	2	2400	2	2400	2	1175	2	2010
4800x2030				2080								2040
4800x2100				2150								2110

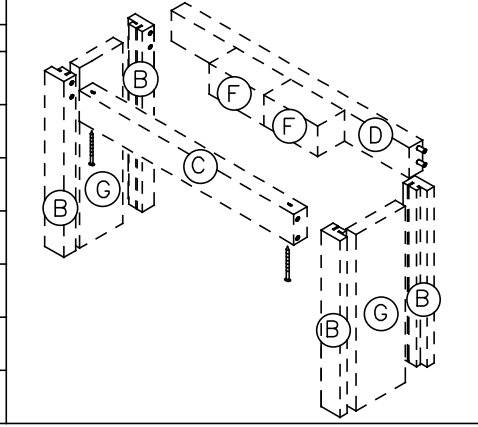

STIPITE NON DISPONIBILE DA SCRIGNO

