

SYSTEMS WITH SWING DOOR FLUSH WITH WALL DOOR CONSTRUCTION **B50**

CAUTION: THE INDICATIONS PROVIDED ARE VALID IF THE MEASURED OPENING COINCIDES WITH THE COMMERCIAL ONE INDICATED IN THE LABELLING OF THE PRODUCT. THE DOOR IS SIZED FOR A 5-mm FLOOR AND DOOR JOINT

KEY:

- L = NOMINAL OPENING
- H = NOMINAL HEIGHT
- LT = NOMINAL (L) + 20mm
- Hp = NOMINAL (H) + 5mm
- X = Hp - 605 mm / 2
- Y = 190 mm (FIXED VALUE only H > 2200)

PULL LEFT AND PUSH RIGHT

Det. "A"

PULL RIGHT AND PUSH LEFT

*** CAUTION**
always check that the frame is correctly installed by measuring the value from the finished floor to the cutaway of the first hinge, which must be 135 mm.

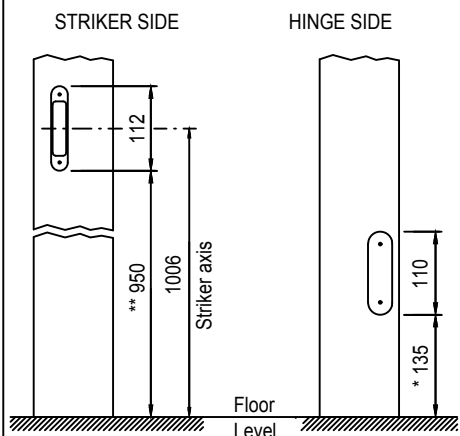

* If different from 135 mm the calculation formulas are not suitable for the construction of the door.

**Detail of processing for hinge
Anselmi art. 505**

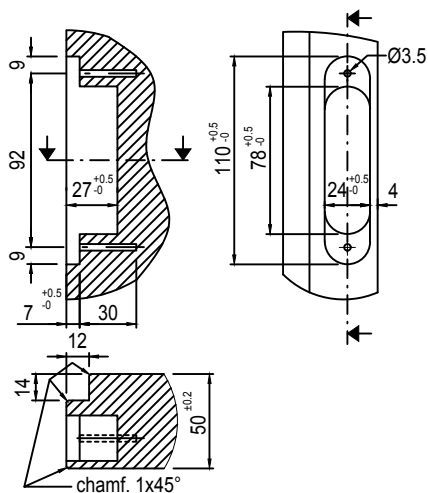

No. 3 hinges for height H from mm 1800 to 2200

No. 4 hinges for height H from mm 2201 to 2700

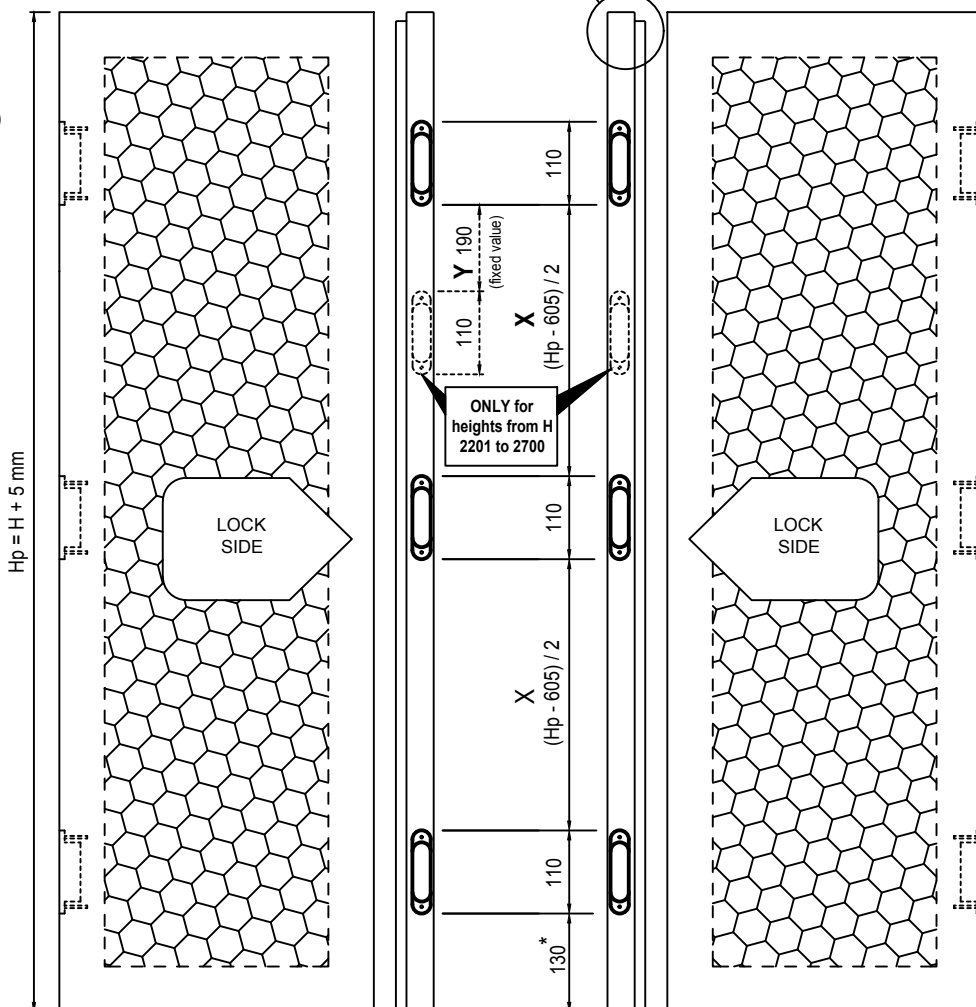

Det. "B"

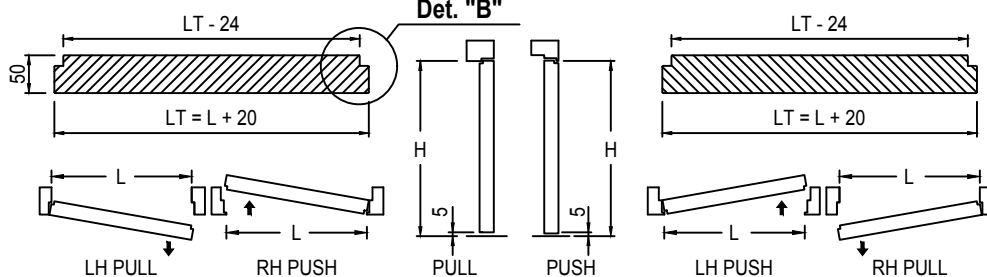

Detail "A"

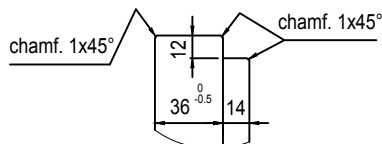

Detail "B"

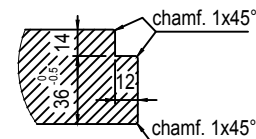

Ces informations sont remises a titre indicatif. SCRIGNO S.p.A. Unipersonale declina toute responsabilite en cas d'erreur d'impression, de traduction, ou pour tout autre motif. Elle se reserve le droit d'apporter toute modification pour le montage et l'amelioration du produit sans preavis. Toute reproduction meme partielle de ce document est formellement interdite.

Los datos publicados son indicativos. La sociedad SCRIGNO S.p.A. Unipersonale declina toda responsabilidad por los posibles errores contenidos, debido a errores de imprenta, de transcripcion o cualquier otro motivo y se reserva el derecho de mejorar los productos sin previo aviso. La reproduccion total o parcial esta prohibida por la ley.

I dati pubblicati sono indicativi. Scrigno S.p.A. Unipersonale declina ogni responsabilita' per le possibili inesattezze contenute, dovute ad errori di stampa, di trascrizione o per qualsiasi altro motivo e si riserva il diritto di apportare modifiche atte a migliorare i prodotti senza preavviso. La riproduzione anche parziale e' severamente vietata a norme di legge.

The information given in this document is for descriptive purposes only. SCRIGNO S.p.A. Unipersonale will not be held responsible for any inaccuracies caused by printing errors, transcription errors or for any other reason, and reserves the right to make modifications, without giving prior notice, for the improvement of its products. The reproduction, including the partial reproduction, of this document is severely prohibited within the terms of the Law.

Bei den veröffentlichten Daten handelt es sich um Richtwerte. Die Scrigno S.p.A. Unipersonale lehnt jegliche Haftung für auf Druckfehler oder andere Ursachen zurückzuführende Ungenauigkeiten ab, und behält sich das Recht vor, jederzeit ohne Vorankündigung Verbesserungen am Produkt vorzunehmen. Der Nachdruck ist auch auszugsweise gesetzlich untersagt.

SCRIGNO

Scrigno S.p.A. Unipersonale
Via Casale, 975 - 47822 - Sant'Ermete di Santarcangelo (RN) - Italy
Tel. +39 0541 757711 - Fax +39 0541 757780
www.scrigno.net e-mail: scrigno@scrigno.it

Detail of processing for magnetic lock Bonaiti B FOUR E=50

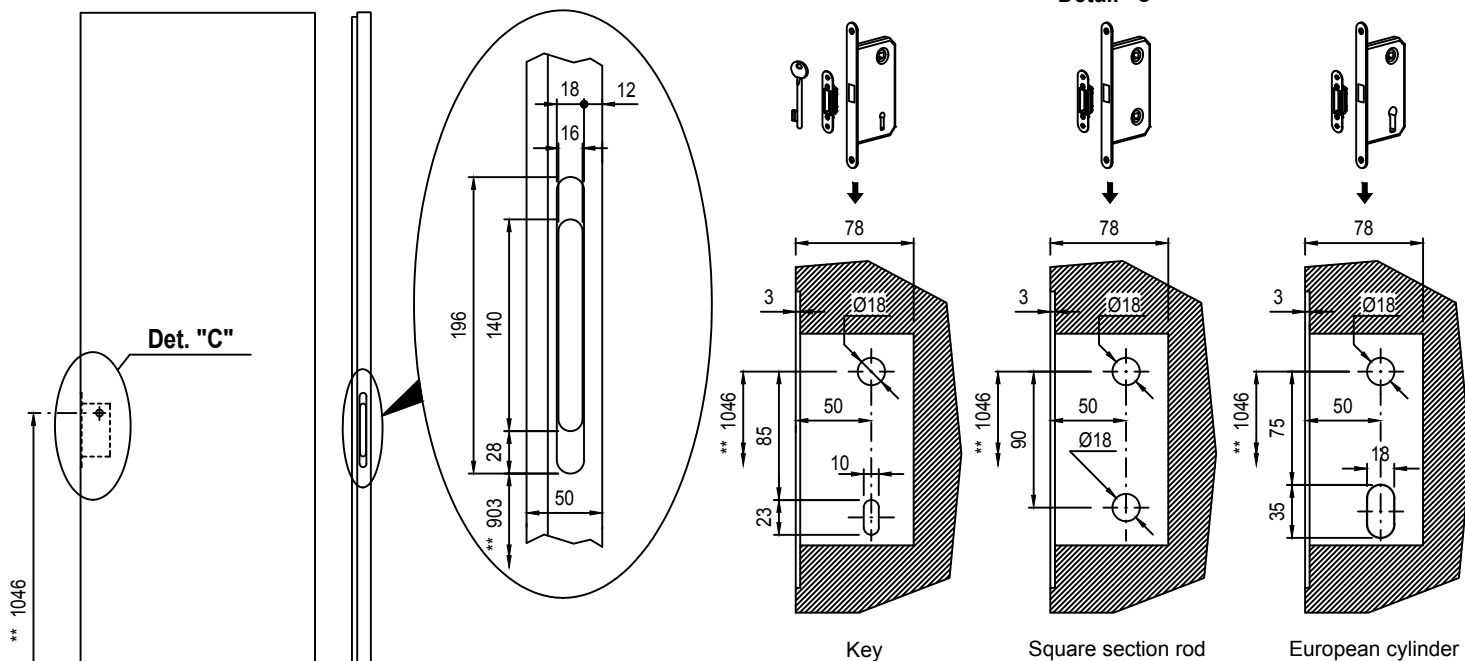

**** CAUTION**

always check that the frame is correctly installed by measuring the value from the finished floor to the cutaway of the striker, which must be 950 mm. If different from 950 mm the dimensions are not suitable for the construction of the door.

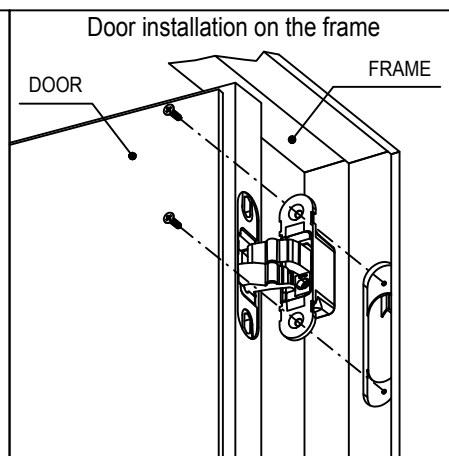
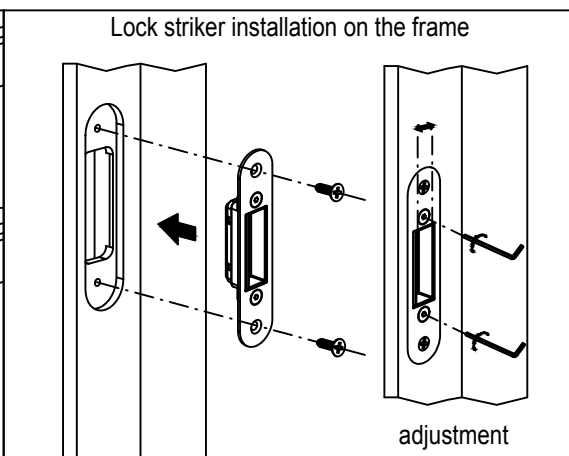
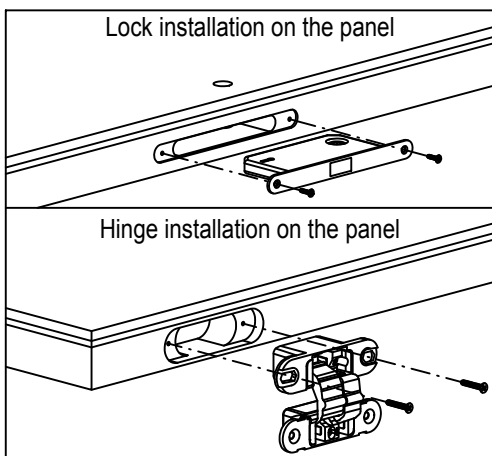

Hinge adjustments

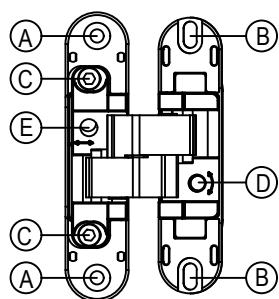

A Hole for screws securing hinge to frame.
B Slotted holes for vertical adjustment and securing to door.

C Depth adjustment securing screw.
D Self-locking screw for lateral adjustment.

E Depth adjustment cam.

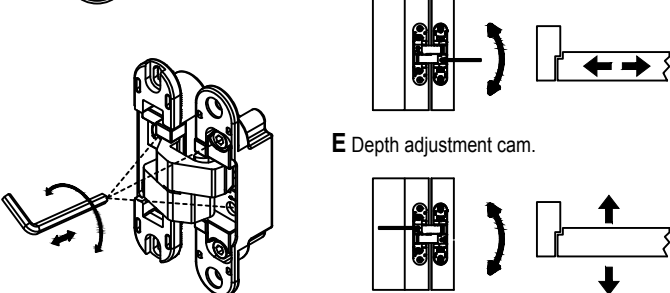

Frame painting

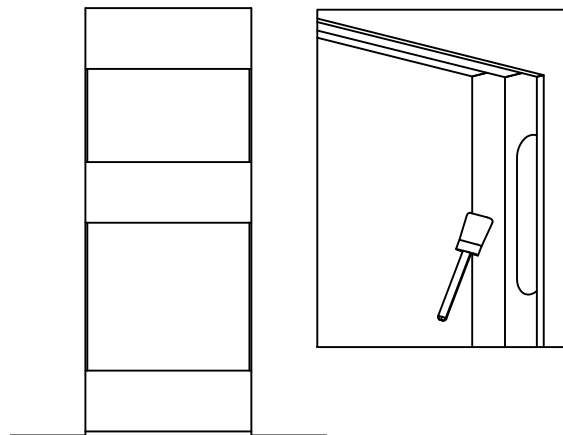

Remove the wooden spacers. Grout the screw holes. Clean the aluminium frame from any cement residue, then colour. Apply suitably diluted cementite as first coat. Install the gasket in the perimeter of the entire frame.
Caution: avoid heavy thicknesses or accumulation of paint which could affect the movement of the panel.